

# Transplant Systems

P.O. Box 295, 63 Enterprise Avenue, Berwick, Victoria, 3806 ABN:87 050 197 012



- Individually built
- Made to order
- Demountable counterweights
- Hydraulic suspension\*
- Double width tyres\*
- Wide 13" rear tyre
- Powerful Kubota diesel engine
- 12 months warranty
- 1.5 Tonnes lift capacity

\*Options available at extra cost upon request.

The Transplant Systems Prins forklift is ideal for use on the nursery. Compact, maneuverable and has a good lifting capacity.

Used with the Demtec Buffer System for pot handling. The Prins truck offers good weight distribution over the ground due to its broad tyres. For growers looking for even better load shedding then double width tyres are also available. Hydraulic suspension ensures a smooth ride for driver and plants!

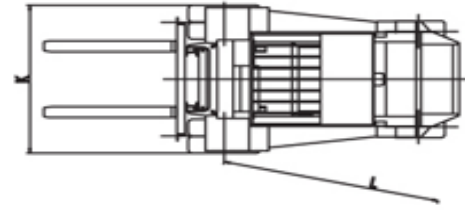
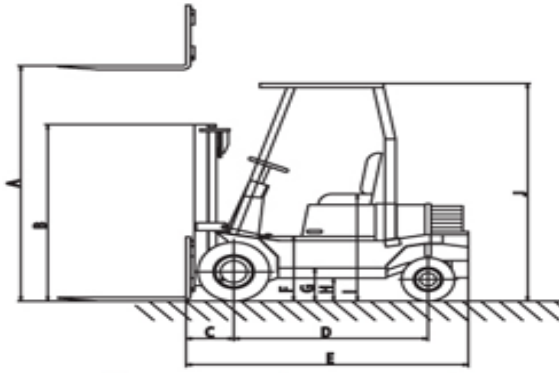

Model	Boxer 1.5	
Load capacity (kg)	1500	
Center of gravity (mm)	500	
Mast angle front/rear	6°/6°	
Fork plate	FEM 2b	
Type of engine	diesel	
Transmission	automatic	
Engine	Kubota V1505	
Power (kW)	24	
Speed (km/hr)	24	
Weight (kg)	2370	
Tires front (Std.)	6.5-80.12	26x12.12
Tires rear (Std.)	18.8-5.8	20x10.10
A (mm)	2800	2800
B (mm)	1970	1970
C (mm)	420	450
D (mm)	1560	1560
E (mm)	2420	2470
F (mm)	650	680
G (mm)	340	370
H (mm)	155	185
I (mm)	1040	1070
J (mm)	2110	2140
K (mm)	1400	1400
L (mm)	2050	2050



**Transplant Systems Pty Ltd**

P.O. Box 295, 63 Enterprise Avenue,  
Berwick, Victoria.  
Tel: 03 97 699733, Fax: 03 97699722

[mike.walker@transplantsystems.com.au](mailto:mike.walker@transplantsystems.com.au)  
[www.transplantsystems.com.au](http://www.transplantsystems.com.au)